

J. T. B. SIDÉN.

TOOL FOR MAKING SPIRAL SPRINGS.

No. 360,623.

Patented Apr. 5, 1887.

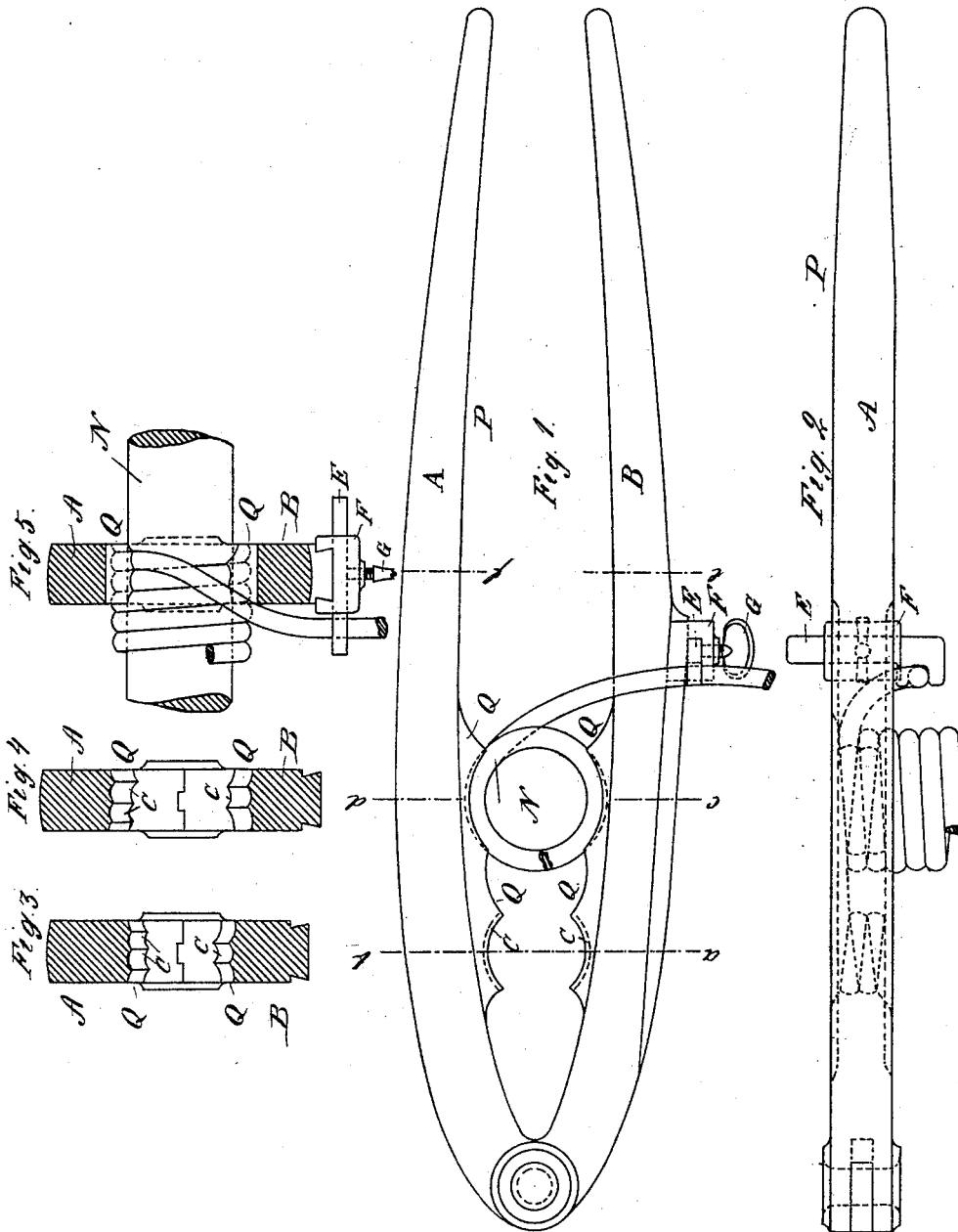

Witnesses:  
*C. Sedgwick*  
*Edgar Tate*

Inventor:  
*J. T. B. Sidén*  
 By *Munn & Co*  
 Attorneys.

J. T. B. SIDÉN.

TOOL FOR MAKING SPIRAL SPRINGS.

No. 360,623.

Patented Apr. 5, 1887.

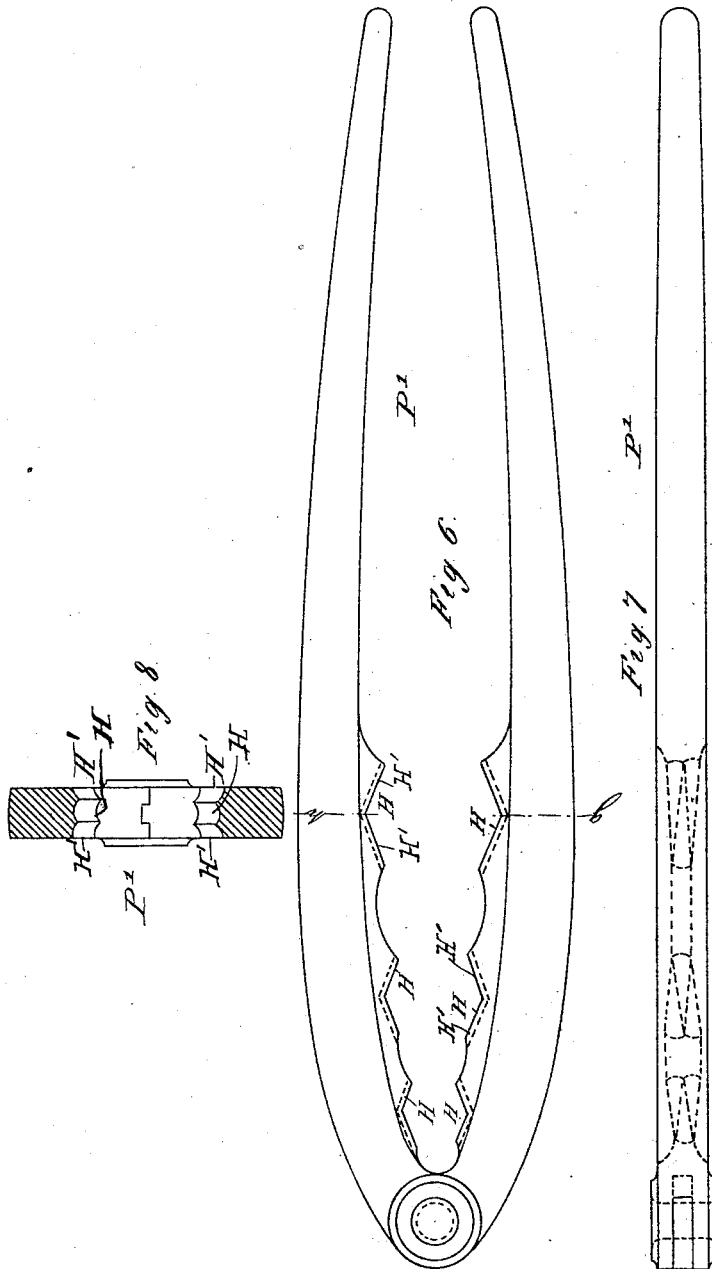

Witnesses:  
 C. Sedgwick,  
 Edgar Tate.

Inventor:  
 J. T. B. Sidén  
 By Munn & Co  
 Attorneys.

# UNITED STATES PATENT OFFICE.

JOHAN THEODOR BERNADOTTE SIDÉN, OF NYBO, WALBO, SWEDEN.

## TOOL FOR MAKING SPIRAL SPRINGS.

SPECIFICATION forming part of Letters Patent No. 360,623, dated April 5, 1887.

Application filed January 7, 1886. Serial No. 187,843. (Model.)

*To all whom it may concern:*

Be it known that I, JOHAN THEODOR BERNADOTTE SIDÉN, of Nybo, Walbo, Sweden, have invented certain new and useful Improvements in Tools for Making Spiral Springs, of which the following is a full, clear, and exact description.

The object of my invention is to provide a new and improved tool for winding or coiling hardened steel wire into cylindrical or conical spiral springs.

The invention consists in various parts and details, as will be hereinafter more fully described and claimed.

Reference is to be had to the accompanying drawings, forming a part of this specification, in which similar letters of reference indicate corresponding parts in all the figures.

Figure 1 is a side elevation illustrating my improved tool for making spiral springs. Fig. 2 is a plan view of the tongs shown in Fig. 1. Fig. 3 is a cross section on the line *a b*, Fig. 1. Fig. 4 is a similar cross-section on the line *c d*, Fig. 1. Fig. 5 is a similar cross-section on the line *e f*, Fig. 1. Fig. 6 represents a modification illustrating a side elevation of a pair of tongs. Fig. 7 is a plan view of the same. Fig. 8 is a cross-section of the same on the line *g h*, Fig. 6.

The mandrel *N*, upon which the wire is to be coiled, is placed in a lathe, which imparts a rotary motion of suitable speed to the mandrel *N*. The steel wire to be coiled is wound on a reel, which is placed near the mandrel *N*, so that in unwinding the wire from the reel it will retain its curved shape as much as possible. One end of the steel wire is fastened to the mandrel *N* in any suitable manner, and a few turns are given to the mandrel by means of the lathe, so as to coil the wire upon the same. The coiled portion of the wire is then grasped with a pair of tongs, *P*, which consists of the legs *A B*, united at one end by a hinge. The inner edge of each of these legs *A* and *B* is provided with one, two, or more jaws, *Q*, having threads *C*, which correspond in size and pitch to the steel wire to be coiled. The ridges between the threads *C* do not penetrate between the different layers of the coiled wire on the mandrel *N*, so that the layers of the coiled wire are not separated.

The jaws *Q*, as represented in the drawings, are of different diameters, to admit of using mandrels of different sizes with one pair of tongs. The tongs grasp the wire in such a manner that the thread of the lower jaw is placed on the last layer of the coiled wire and the thread of the upper jaw on the two last layers of the coiled wire. The prongs *A* and *B* of the tongs *P* are then pressed inward toward each other by means of the tong-rings or other suitable devices, after which the mandrel *N* is rotated a few times by means of the lathe. The prongs are then pressed still farther toward each other, but not enough to injure the wire to be coiled. That portion of the wire which runs off of the reel, and has heretofore laid on that side of the jaw on which the coiling is performed, is now brought over to the opposite side—that is, the side from which the coil runs—and is placed in a slot or recess formed in the holder *E*, which is held adjustably in a sliding keeper, *F*, attached to the lower edge of the prong *B* by a dovetail, and which keeper *F* can be secured to the leg *B* by means of the thumb-screw *G*. As the wire comes from this side of the prongs, a portion of the wire which runs off the reel is bent toward the last coiled layer, so that the different layers of the coil-spring, when the same has been removed from the mandrel, have a tendency to press against each other, which they would not do if the wire had entered the jaws from the opposite side. As the wire is pressed on the mandrel *N* at the point of contact with the outer thread of the jaws, it insures a better bending of the wire next to the last layer. The extent of this bending is regulated by moving the holder *E* across the leg *B*, and the bend given to the wire governs the initial bearing capacity of the finished spring, thereby making the spring more valuable.

To prevent the wire from adhering to the jaws of the tongs when the same are open, a lubricator may be placed in a suitable position on the legs, so as to moisten the outside of the wire to be coiled.

Cone-shaped spiral springs are made by using a tapering mandrel and having a pair of tongs, *P'*, as illustrated in Figs. 6, 7, and 8, each of the jaws *H* of which is formed of two straight sides, *H' H'*, which are at an angle of

ninety or one hundred and twenty degrees to each other. With the straight sides of the jaws H of the form of tongs illustrated in the just-referred-to figures, the wire is not liable to be wedged or pinched during the coiling of the same, as in the use of the semicircular-faced jaws, since in the former the continuous grooved surfaces or faces of the jaws are not in contact with the wire, as in the latter, being divided up into a number of points of contact, thus securing the result as above given. A cylindrical spring having on one or both ends a conical spiral spring is made by first coiling the cylindrical spring on the mandrel by the tongs P, above described, and then coiling the conical part of the spring on a tapering mandrel by the tongs P' in the same manner.

The cylindrical springs are cut off at suitable lengths, and the ends of the springs are carefully tempered and annealed in that portion which is to be made conical.

If wire of a large diameter is to be coiled, the tongs can be so arranged that one leg is attached to a bench or vise, and the other prong is provided with a handle, to enable the

operator to press with both hands on the prong connected with the handle.

Having thus fully described my invention, I claim as new and desire to secure by Letters Patent—

1. In a tool for making spiral springs, a pair of tongs having its legs united at one end and provided with threaded jaws, in combination with a holder adjustable in a keeper having a sliding connection with one of the legs, substantially as and for the purpose set forth.

2. In a tool for making spiral springs, a pair of tongs having its legs united at one end and provided with threaded jaws, in combination with a holder adjustable in a keeper sliding on a dovetail formed on the under side of one of the said links, substantially as and for the purpose set forth.

In witness whereof I have hereunto signed my name in the presence of two subscribing witnesses.

JOHAN THEODOR BERNADOTTE SIDÉN.

Witnesses:

NERE A. ELFWING,  
H. ANDERSSON.